



**SEIXAS & FILHOS**  
HOLDING LTD.



## OPERAÇÕES E PERFIS

APRESENTAMOS AS DIVERSAS OPERAÇÕES QUE O NOSSO EQUIPAMENTO PERMITE EFECTUAR BEM COMO RESPECTIVAS MEDIDAS DE PERFIS. QUALQUER DUVIDA OU ESCLARECIMENTO CONTACTE-NOS PELO TELEFONE +351 212 242 187 OU VIA E-MAIL PARA [INFO@SEIXASEFILHOS.COM](mailto:INFO@SEIXASEFILHOS.COM).

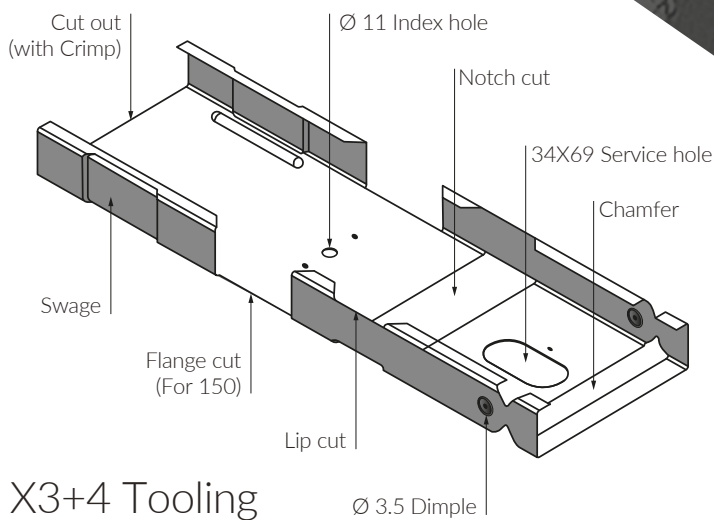

X3+4 Tooling

Perfil	Tipo	Área [m <sup>2</sup> ]	Peso Kg/ml
C	C150x41x1.0	2,45E-04	1,92
	C150x41x1.2	2,92E-04	2,29
	C150x41x1.5	3,63E-04	2,85
	C90x41x1.0	1,85E-04	1,45
	C90x41x1.2	2,20E-04	1,73
	C90x41x1.5*	2,73E-04	2,14
	C75x41x1.0*	1,70E-04	1,33
	C75x41x1.2*	2,02E-04	1,59
	C75x41x1.5*	2,51E-04	1,97
	U	U153x40x1.5	3,42E-04
U93x40x1.2		2,03E-04	1,59

\*Fornecimento somente por encomenda

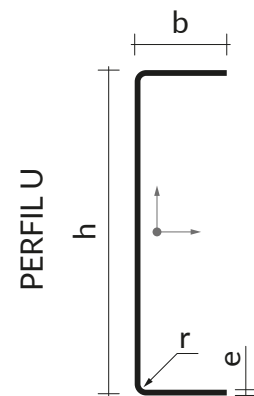
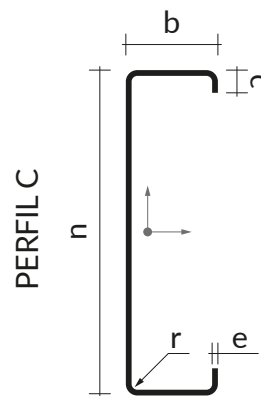

c lip = 12 mm  
b banzo = 41 mm  
n 75, 90 e 150 mm

h 93 mm e 153 mm  
r raio = 1.5  
e espessuras = 1.0 / 1.2 / 1.5 mm